

A real big thing!

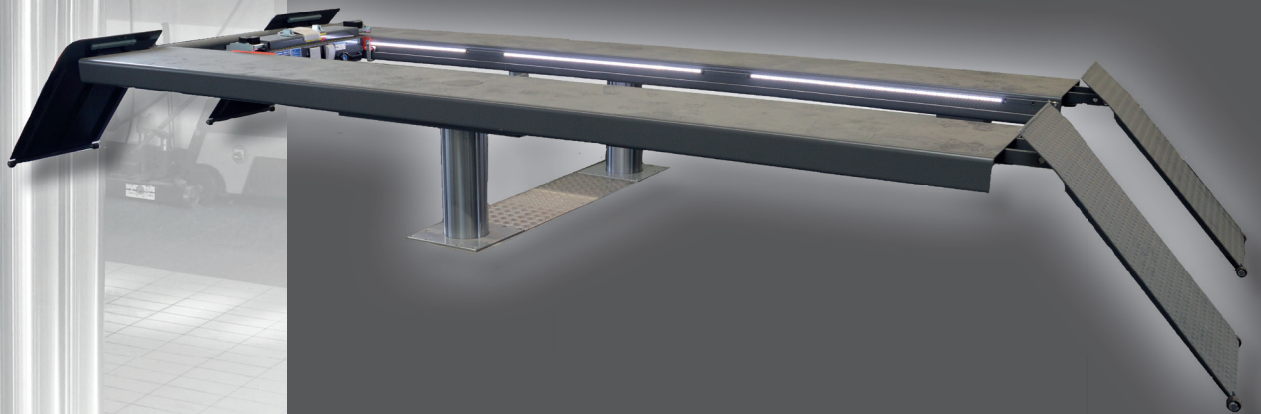

autop Biglift 2.65 F 550

The Biglift 2.65 F 550 has been developed for a quick and easy lifting of commercial vehicles with very different wheel bases. With a lifting capacity of 6,5 t and a platform length of 5.5 m you can even lift up transporters of the newest generations.

The base of the construction is the hydraulic unit with two pairs of inversed and hard chromed cylinders. This new construction points out the following advantages:

- perfect stability
- safe lifting even in case of unfavorable load distribution
- low cost of installation – can be fitted into existing Biglift cassettes
- proven and extremely resistant chrome plated lifting cylinders
- space saving construction
- LED lighting for the vehicle underside
- Jacking beam also for transporter with different wheel bases
- Installation in on-floor and recessed in the floor possible

autop Maschinenbau GmbH

Sandkampstr. 90

D-48432 Rheine

Tel. ++49(0)5971/8602-02

Fax ++49(0)5971/8602-25

E-Mail: mail@autop.de

www.autop.de

...a company of the STENHØJ-group!

Professional lifting technology!

Biglift 2.65 F 550

Components

- two pairs of hard-chromed hydraulic cylinders
- corrosion-free guiding elements
- SPS - control unit
- pneumatic emergency drain
- flexible synchronizing and safety device
- installation in waterproof cassette
- use of „bio-oil“, non hazardous to water
- two on-floor platforms, appropriate drive-on flaps are available
- platforms with anti-sliding surface

Optional:

- jacking-beam
- LED lighting for the vehicle under-side

Standard colour:

RAL 7016 (grey anthracite)

on request

RAL 5019 (blue)

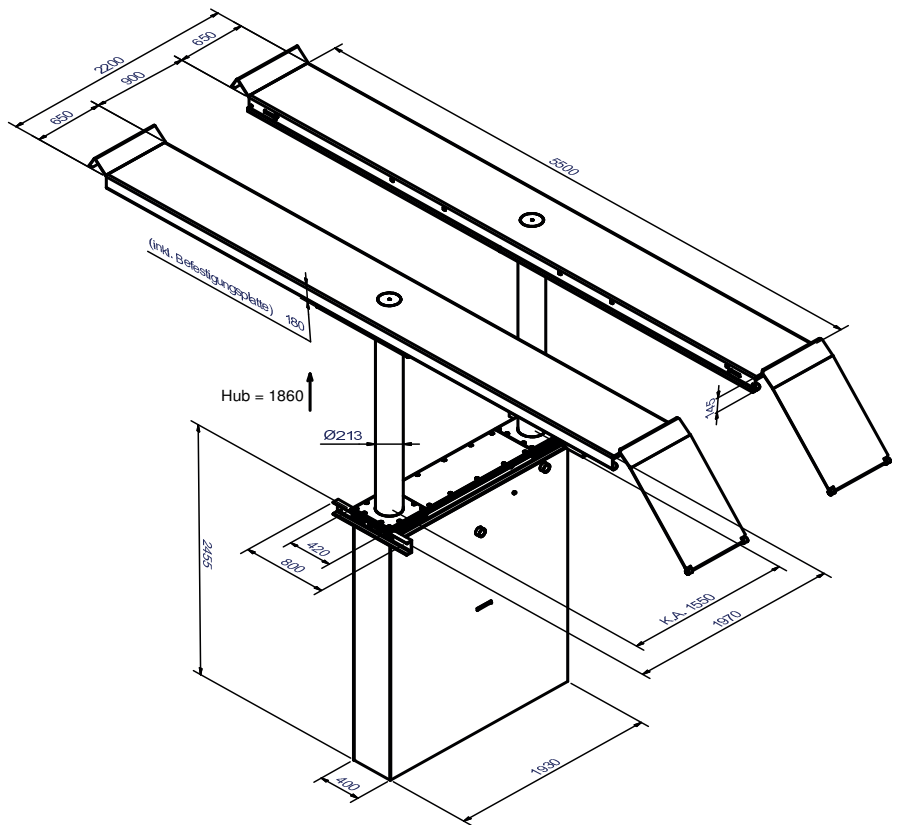

Technical data:

Capacity:	6,500	kg
Piston distance:	1,550	mm
Cylinders' diameter:	2 x 213	mm
Lifting/lowering time:	appr. 45	sec.
Stroke length:	1,865	mm
Lifting height:		mm
Foundation depth:	2,665	mm
Voltage:	230/400	V
	50	Hz
	16	A
Power unit:	3.0	kW

Platform:

Length:	5,500	mm
Width:	650	mm
Wheel-base, max.:	4,900	mm
Drive-over height:		mm

Jacking beam

Capacity:	2,600	kg
Lifting height:	210	mm
3-points lifting:	middle/690-1500	mm
Function:	air-hydraulic	
Drive-over height:	215	mm

Service:

Our expert consultants would appreciate to help you with the planning of a new garage or the modernization of an existing one. We offer to work out a workshop concept incl. an equipment proposal.

Please do not hesitate to contact us!

autop Maschinenbau GmbH

Sandkampstr. 90

D-48432 Rheine

Tel. ++49(0)5971/8602-02

Fax ++49(0)5971/8602-25

E-Mail: mail@autop.de

www.autop.de

...a company of the STENHØJ-group!



No liability accepted for specifications that are subject to alteration - validity 1.2.2015. The date and pictures in this product information are not binding and are only giving an approximate description. Moreover we reserve the right of differences between the goods delivered and the date and pictures given here (i.e. technical data, equipment, material and optical appearance) so far as the differences are reasonable for the customer and a possible reduction in value of the goods delivered is not considerable.